

Flowgrid™ Valve

10" Dual Port V-6

Flanged CL 150-600

The 10" Dual Port V-6 **Mooney™** Flowgrid Valve is an economical and easy to maintain pilot operated valve for both gas and liquid applications. The valve can be used with dual pilots for redundant control (acts as two regulators in parallel), but is primarily a large capacity valve that can be maintained by one person. The ports are mounted at 45 degree angles for easy in line maintenance. The low profile makes it ideal for skid mounted, vault, and enclosure installations.

Specifications

Size	10"
Body Style	Dual Port (10")
End Connections	10" CL 150, 300, 600 Flanged
Temperature	Working -20°F to 150°F Emergency -40°F to 175°F
Max. Operating Differential	800 psi
Max. Emergency Differential	1000 psi
Min. Differential	Refer to graph on page 2
Cracking Differential	Refer to graph on page 2
Max. Inlet Pressure	1480 psig ¹
Outlet Pressure Range	Limited By Pilot
Flow Direction	Bi-Directional ²
Body Taps	Four 1/4" - 18NPT

1. Limited by pilot or flange rating.
2. Reverse flow by changing pilot connections and reversing spring case.

Materials of Construction

Body and Spring Case	ASTM A 216 GR WCB Carbon Steel
Throttle Plate	17 - 4PH Stainless Steel
Diaphragm	Nitrile/Nylon ¹
O-Ring and Seals	Nitrile
Bolting	ASTM A 193 GR B7 or Equal
Spring	301 Stainless Steel

1. Refer to diaphragm selection chart on page 2.

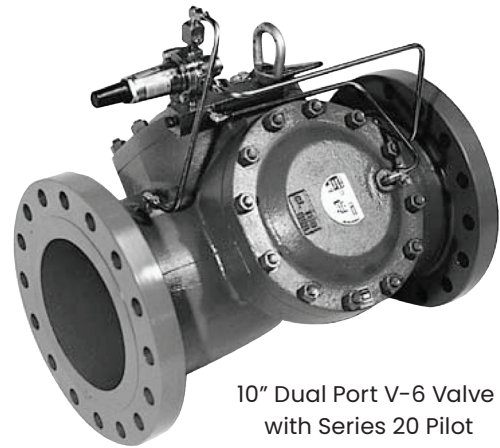

10" Dual Port V-6 Valve
with Series 20 Pilot

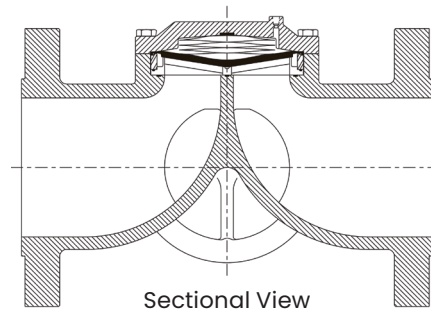

Sectional View

Overpressure Protection

The Flowgrid Valve is bi-directional and has a full ASME rating on both the inlet and outlet. Overpressure protection is required only if the pressure can exceed the flange or body rating.

The pilots, like most regulators, may have an outlet pressure rating lower than the inlet pressure rating. If this is the case, then some external form of over-pressure protection must be provided for the pilot.

Anytime the Flowgrid valve or pilot system is exposed to pressure in excess of its rating, it should be inspected for damage.

Stock Numbers

10" Dual Port Valve	Stock Number	Weight
150# Flange	FG-57	590 lbs.
300# Flange	FG-58	670 lbs.
600# Flange	FG-59	900 lbs.

Dimensions

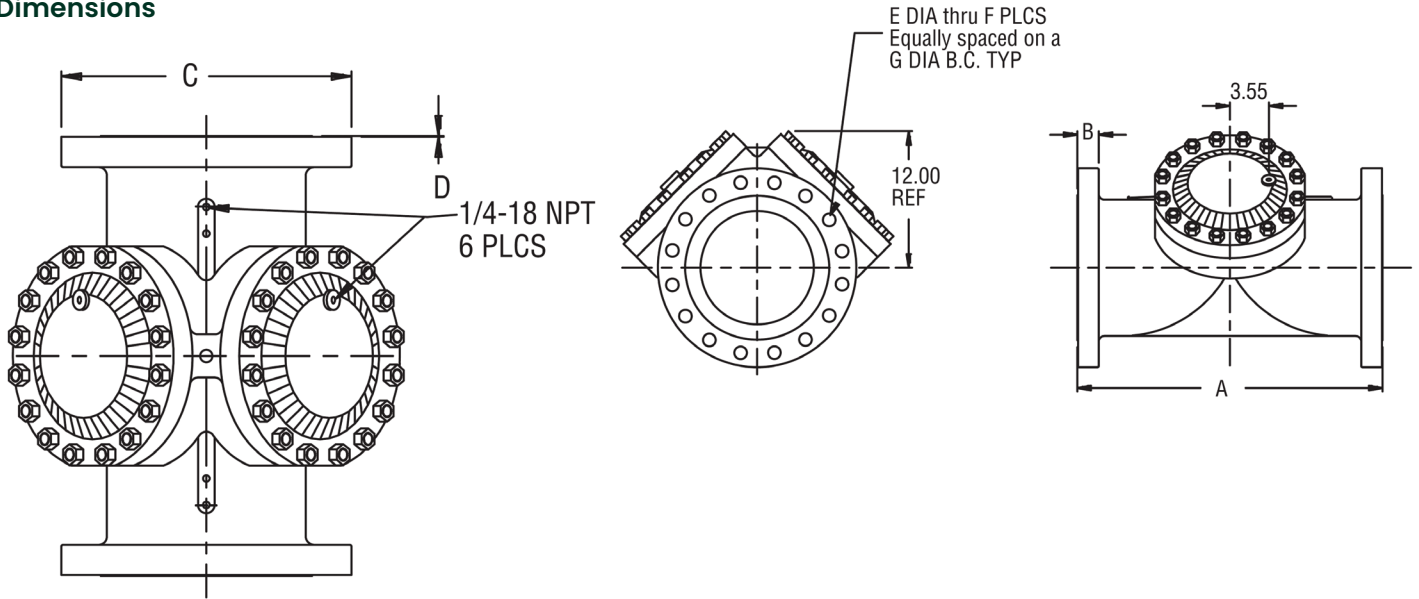

Minimum Pressure Differential vs. Capacity

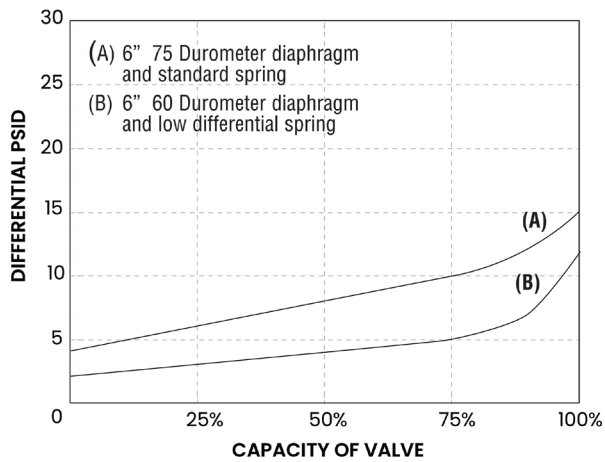

Dimensions

End Connection	A	B	C	D	E	F	G
150# Flange	26.50	1.19	16.00	0.062	1.00	12	14.25
300# Flange	27.88	1.88	17.50	0.062	1.12	16	15.25
600# Flange	29.60	2.75	20.00	0.250	1.38	16	17.00

Flow Coefficients and Constants

% Capacity	10" Dual Port Valve			Swage Factor	
	C _v	C ₁	C _g	1.5:1	2:1
100%	650	33	2000	1.00	0.99
75%	550	30	16500	1.00	0.99
50%	472	28	13200	1.00	0.99
35%	290	27	7830	1.00	1.00

Note: Allow a 5% factor of safety when calculating relief capacity.

Diaphragm Selection

Compound	Temp. Range (°F)	Maximum Differential	Characteristics	Recommended Applications
75 Duro	-20 to 150	1000 psid	Best All Around Material	60 psid to Max. Differential
60 Duro	-25 to 150	300 psid	Best Shutoff at Low Differential Pressure	Low Differential (100 psid or less) or Low Temperature
80 Duro High ACN	-5 to 175	1000 psid	Higher Abrasion and Swelling Resistance	High Differential (400 psid or higher) or Abrasive Conditions with Distillates
80 Duro Low ACN	-20 to 150	1000 psid	Higher Abrasion Resistance and Low Temperature Flexibility	High Differential (400 psid or higher) or Abrasive Conditions at Low Temperatures

Baker Hughes