

# Instruction Manual for the HPP-5 High Pressure Positioner

## Table of Contents

<u>Section</u>	<u>Page</u>	<u>Section</u>	<u>Page</u>
<b>Introduction</b>	2	<b>Changing Positioner Action</b>	12
Description	2		
Scope of Manual	2	<b>Conversion to Split Range</b>	13
Technical Assistance	2		
Applications	3	<b>Assembly Procedures</b>	Separate Manual
Guidelines for usage	3		
<b>Technical Information</b>	4	<b>Inspection Procedures</b>	15
Specifications	4		
Materials of Construction	4	<b>Parts Ordering</b>	16
Accessories	4	Parts List	16
		Seal Kits	16
<b>Principals of Operation</b>	5	<b>Appendix – Parts &amp; Mounting detail</b>	
Close on increasing	5	Open on increasing (parts)	18
Open on increasing	6	Close on increasing (parts)	19
<b>Adjustment Procedure</b>	7		
Deadband Setting	8		
Bias Adjustment	9		
Range Adjustment	10		

## **Introduction**

The **Becker HPP-5** series positioner represents a breakthrough in valve control technology for the natural gas industry. Built to exacting specifications, the easily maintained unit offers highly accurate control with excellent control characteristics in a broad range of operating environments. The **HPP-5** series positioner is designed such that upon reaching a valve position and achieving a steady state, the gas consumption is very low. Additionally, its bleed gas can be routed to a lower pressure downstream or fuel gas system, eliminating bleed gas completely. This means significant savings to your company in terms of minimizing expensive bleed gas as well as a cost saving means of minimizing the environmental impact of atmospheric hydrocarbons and diminishing natural resources.

## **Description**

The **Becker HPP-5** positioner is used in control valve assemblies with a controller or I/P transducer and double acting actuator to provide accurate flow or pressure control. The **HPP-5** can be used with various valve types that utilize a double acting pneumatic piston actuator. The **HPP-5** design positioner represents Becker's commitment to continuous development of new products and updating of existing products to maximize their performance while retaining simple operation and minimum maintenance.

Valves over 16" in diameter require the use of a **Becker HPP-4** positioner with Volume boosters.

## **Scope of Manual**

This manual provides information on installation, operation, adjustment, and maintenance of the **Becker HPP-5** positioner. For information concerning actuators, valves, and accessories, refer to the instruction manuals provided with the specific product.

**Note:** *Only those qualified through training or experience should install, operate, or maintain **Becker** positioners. If there are any questions concerning these instructions, contact your Becker sales representative, sales office, or manufacturer before proceeding.*

## **Technical Assistance**

Should you have any questions, you may contact your local Becker Precision sales representative or Becker Precision technical assistance at:

### **Becker Precision Equipment, Inc.**

Attn: Technical Assistance  
950 Pratt Boulevard  
Elk Grove Village, IL 60007 USA

Toll Free: (800) 323-8844  
Tel: (847) 437-5940  
Fax: (847) 437-2549  
e-mail: becker@bpe950.com

## **Applications**

- Primary Pressure Control
- Overpressure Protection (Monitor)
- Underpressure Protection (Standby)
- Relief Valve
- Backpressure Control
- Power Plant Type Applications\*
- When Unique "Bleed to Pressure System" **BPS™** feature can be utilized
- Any large downstream systems (city gate stations, inter-system pressure limiting)
- Suction control to reciprocating compressors\*
- Double-stage cut (working monitor regulator\*)

\* (consult Becker for additional information)

## **Guidelines for Usage**

*Large Volume Control Valve Actuators:* Control Valves that require large volume actuators may require Model VB-250 Volume Boosters to ensure adequate stroking speed. HPP-5 positioners are NOT compatible with volume boosters. The HPP-4 positioner must be used

*Bleed to Pressure System:* The HPP-5 Positioner is typically utilized for applications where no discharge pressure of less than 350 psig is available. The very low steady state bleed of the positioner makes it efficient for minimizing atmospheric emissions. The HPP-5 is also compatible with the Becker BPS (Bleed to pressure system).

*High Gain Systems:* The HPP-5 is not preferred for this application. It may be successfully used with small diameter (4" and smaller) ball valves for this application, but its limited orifice capacity makes it too slow for controlling larger valves on short systems.

*CVE Globe Pattern Control Valves:* The Becker HPP series positioners are compatible with the Globe style control valve, but require a minimum of 2" of actuator stroke for proper feedback and operation. This makes it impossible to use this positioner with most globe valves smaller than 4" port size.

### **Compatible Actuators:**

- Becker RPDA Actuators (Rotary Piston Double-Acting)
- Becker LPDA Actuators (Linear Piston Double-Acting)
- Other manufacturer's double-acting piston actuators\*

\*consult Becker for additional information

### **Retrofit Compatibility:**

Optimum performance is achieved by pairing the HPP-5 with genuine Becker control valve actuators. Should you already have existing control valve actuator (s) in service, the addition of a Model HPP-5 can improve performance and eliminate atmospheric bleed emissions if using the BPS (Bleed to a pressure system) feature.

Some Compatible Actuators:

- Bettis T-Series Piston Actuators
- Fisher Type 470 Piston Actuators
- Fisher Type 1061 Piston

**Technical Specifications**

<b>Input Signal:</b>	<i>Standard:</i> 3-15 psi or 6-30 psi. <i>Adjustable:</i> Zero is adjustable from 2-30 psig, span is adjustable from 5-24
<b>Output Signal:</b>	Pneumatic pressure as required by the actuator up to full supply pressure.
<b>Loss of Signal:</b>	<i>Reverse Acting:</i> Open on loss of signal. <i>Direct Acting:</i> Close on loss of signal.
<b>Connections:</b>	All Ports: ¼" N.P.T.
<b>Action:</b>	<i>Direct and Reverse Acting:</i> . Field-reversible
<b>Performance:</b>	<i>Resolution:</i> 0.4%* <i>Hysteresis:</i> .6%*
<b>Flow Capacity:</b>	C <sub>v</sub> = 1.5
<b>Steady State Consumption:</b>	Near Zero
<b>Power Gas Requirement:</b>	Use clean, dry filtered (100 micron) gas. <i>Discharging to Atmosphere:</i> 150 psig maximum.
<b>Operative Temperature Limits:</b>	20 to 160°F (-28 to 70°C).
<b>Housing:</b>	Meets NEMA 3 classification (weather tight).
<b>Installation Orientation:</b>	Vertical or horizontal position allowable.
<b>Approximate Weight:</b>	15 pounds.

\* Resolution and repeatability figures reflect a positioner that is adjusted with a minimum deadband to reduce bleed gas. If the deadband is eliminated (slightly increasing the bleed gas), resolution and repeatability will improve.

**Materials of Construction**

<b>External Parts:</b>	Anodized 2024 Aluminum
<b>Internal Parts:</b>	316 Stainless Steel and 2024 Anodized Aluminum
<b>Feedback Lever:</b>	316 Stainless Steel
<b>Range Spring:</b>	Plated Music Wire
<b>Diaphragms:</b>	Buna-N with Nylon Reinforcement
<b>Seats and O-Rings:</b>	Buna-N
<b>Tubing:</b>	316 Stainless Steel
<b>Fittings:</b>	316 Stainless Steel
<b>Gauges:</b>	2 ½" Dial Liquid filled Brass Connection with Stainless Steel Case. (Stainless Steel connection optional)

**Maximum Supply Regulator Capacity**

$$Q = 312.86 \times P_1 \times C_v \times \sqrt{\frac{1}{G \times (T + 460)}}$$

Q = Min. Supply Regulators Capacity (scfh)

G = Specific Gravity of Gas

T = 460 + Operative Temperature (°F)

C<sub>v</sub> = Flow Factor

P<sub>1</sub> = Supply Pressure to Positioner (psig)

**Accessories**

- **Atmospheric Bleed Control (AB Control):** maintains minimum pressure differential across the cylinder. The AB Control is required in order to provide the necessary output to operate the control valve under all design conditions.
- NBV No Bleed valve – same function as DPS, no adjustments or tubing required. Works up to 150 psig power gas.
- **DPS Series Non-Bleed Sensor:** achieves non-bleeding conditions in either full open or full closed positions. Selection based upon power gas pressure and discharge gas pressure.

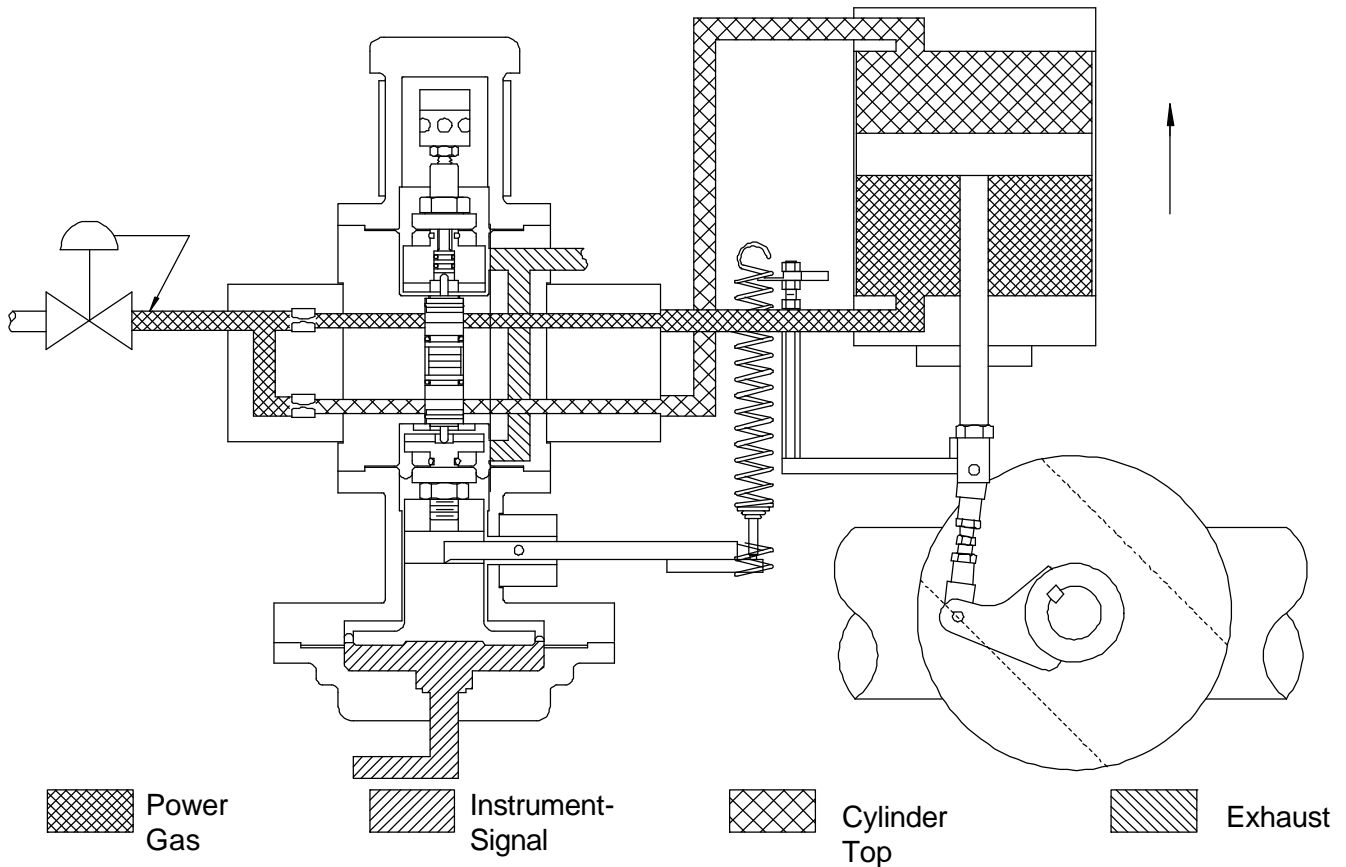

## **Principles of Operation**

### **Close on Increasing Signal**

The positioner is a force-balanced instrument that provides a control valve position proportional to the pneumatic input signal. The control valve will *open* on loss of input signal. The energy to operate the control valve is obtained from the differential between the supply and discharge pressures. In steady state, the forces imposed on the balance beam by the input signal diaphragm and the range spring are equal; therefore, the top and bottom balance valves in the positioner are at or near their closed positions. The cylinder top and bottom pressures are both equal to power gas pressure, and the control valve is stationary. An increase in the input signal pressure results in the opening of the lower balanced valve due to an imbalance in the beam forces. This decreases the pressure in the cylinder top., while the pressure in cylinder bottom remains at power gas. The control valve begins to close. The actuator rod stretches the range spring, increasing its tension. This force, which opposes the force on the balanced beam caused by the increasing input signal, continues to increase until the balance beam forces are in equilibrium. At this point the valve is in the correct position for the applied input signal. The positioner has a sensitivity adjustment which permits a balance between greater accuracy (from a smaller deadband) and minimal bleed gas.

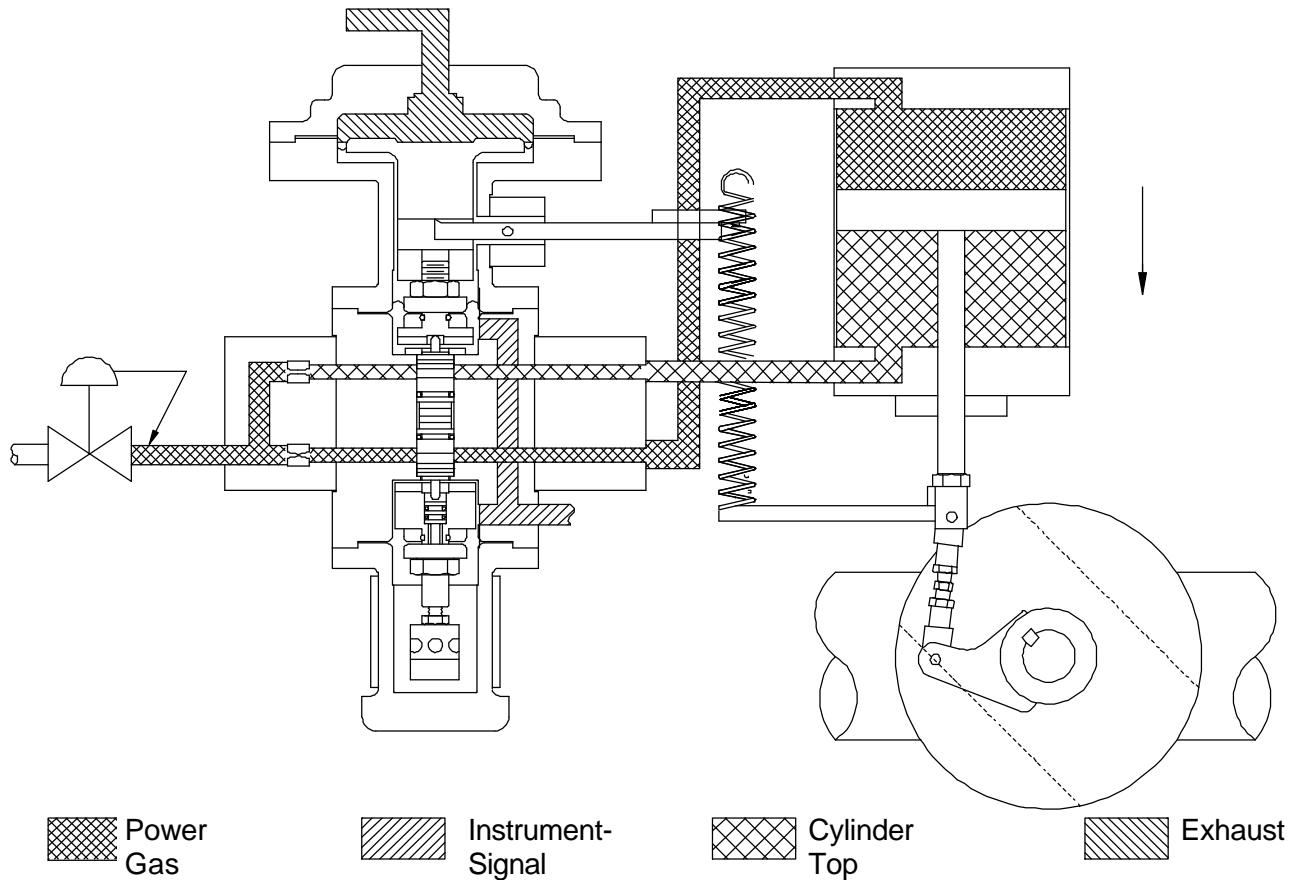

**Open on increasing Signal**

The positioner is a force-balanced instrument that provides a control valve position proportional to the pneumatic input signal. The control valve will *close* on loss of input signal. The energy to operate the control valve is obtained from the differential between the supply and discharge pressures. In steady state, the forces imposed on the balance beam by the input signal diaphragm and the range spring are equal; therefore, the top and bottom balance valves of the positioner are at or near their closed positions. The cylinder top and bottom pressures are both equal to power gas, and the control valve is stationary. An increase in the input signal pressure results in the opening of the upper balance valve due to an imbalance in the beam forces. This decreases the pressure in the cylinder bottom, while the pressure in the cylinder top remains at power gas pressure. The control valve begins to open. The actuator rod stretches the range spring, increasing its tension. This force, which opposes the force on the balanced beam caused by the increasing input signal, continues to increase until the balance beam forces are in equilibrium. At this point the valve is in the correct position for the applied input signal. The positioner has a sensitivity adjustment which permits a balance between greater accuracy (from a smaller deadband) and minimal bleed gas.

Your HPP-5 positioner will come factory adjusted for your particular application. The use of the adjustment procedures will be necessary upon installation of a rubber goods replacement kit or any other disassembly or reassembly of the positioner.

**Adjustment Procedure**

The sensitivity adjustment drum on one end of the positioner determines the sensitivity of the unit.

The variable orifices determine the stroking speed of the positioner.

**Initial Adjustment**

1. Adjust the supply regulator:  
Adjust the supply regulator to the desired Power Gas pressure. Refer to the original invoice paperwork supplied with the product for the appropriate Power Gas pressure setting. It is imperative that adequate supply gas pressure be supplied to the VRP-CH in order to ensure proper operation of the system and all accessories.

2. Adjust the adjustable orifices:  
The adjustable orifices are utilized to control the volume of gas that is supplied to the HPP-5.

The stroking speed of the system is proportional to the numerical value of the adjustable orifice. Adjustable orifice settings are typically equal for both orifices. However, a few applications may require unequal settings for each adjustable orifice. Refer to Fine Tuning for more information on utilizing unequal adjustable orifice settings. Set both orifices according to the table below.

**Notes:**

- To determine the cylinder bore, look at the model number stamped on the stainless steel tag on the top of the cylinder. The cylinder bore will be the first number following the first capital letter "H". This one or two digit number following the first "H" will be the diameter in inches and will be followed by another letter (For example, a unit with the model number 6H8F6FG-H4 has an

**Table A – Exhaust vented to Atmosphere**

SUPPLY PRESSURE (psig)	CYLINDER BORE (IN.)						
	4	5	6	8	10	12	14
	VARIABLE ORIFICE NUMBER						
Up to 50	3	3	3	4	4	5	6
51-200	2	2	3	3	4	5	5
201-600	2	2	2	3	3	4	5

**Table B – Exhaust vented to Pressure System**

SUPPLY PRESSURE (psig)	CYLINDER BORE (IN.)						
	4	5	6	8	10	12	14
	VARIABLE ORIFICE NUMBER						
Up to 50	3	3	3	4	4	5	6
51-200	4	4	4	5	5	6	6
201-600	2	2	2	3	3	4	5



**Deadband Setting**

1. Turn the deadband adjustment drum in the direction of increasing the numbers until the drum can no longer turn. Then turn the adjustment drum one full turn in the opposite direction (use the numbers on the drum as a guide).
2. If not already attached, wind 3-4 coils of the range spring onto the retainer.
3. If not already adjusted, set the bias adjustment screw in the middle of its travel range.
4. Apply power gas to the HPP-5 positioner
5. Set the instrument signal pressure at the midpoint of its range (e.g.. 9 psig for a 3-15 psig range, 18 psig for a 6-30 psig range). Allow the actuator to stroke the valve to an intermediate position and the gauge pressures to balance. (if the valve does not stroke, insure that the positioner is communicating with the actuator cylinder. If equipped with an MCV-3, make sure the MCV-3 left handle is in automatic.

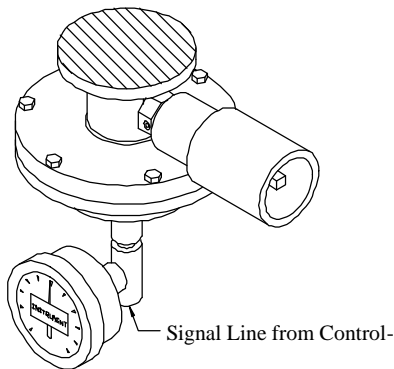

6. If the actuator is equipped with an MCV-3 Manual Control Valve), place the left MCV-3 handle in the manual position. If the actuator is not equipped with an MCV-3, use the block valve (1/4 " ball valve) installed between the positioner output and the actuator. Once the actuator has reached its desired position (based on the mid-signal applied to the instrument port – Step 5), place the block valve in the closed position.

**7. Final Sensitivity Drum Adjustment For positioner's bleeding to atmosphere:**

Disconnect any bug vent or tube fitting from the exhaust port.

Turn the deadband adjustment drum in the direction of decreasing numbers, until the exhaust port begins to bleed gas. Than turn the drum in the opposite direction until the exhaust port just stops bleeding.

The unit is properly adjusted if increasing or decreasing the input signa by .2 psig causes the cylinder top and bottom gauges to develop differential equal to at least 20% of power gas.

Replace the exhaust fitting

**For Positioner's bleeding to a pressure system:**

Slowly decrease the setting of the deadband (decreasing numbers) until both cylinder gauges are equal and read 90 to 95% of power gas pressure.



**Note:** When increasing or decreasing the instrument signal, the output pressure should swing up and down. When changing direction of the false instrument signal, the output pressure should immediately reverse direction. Any “bump” or initial reaction of the gauge in the wrong direction indicates friction (requiring the unit be rebuilt to eliminate the friction).

8. Place the instrument signal to automatic and open the block valves or return the left handle of the MCV to automatic.

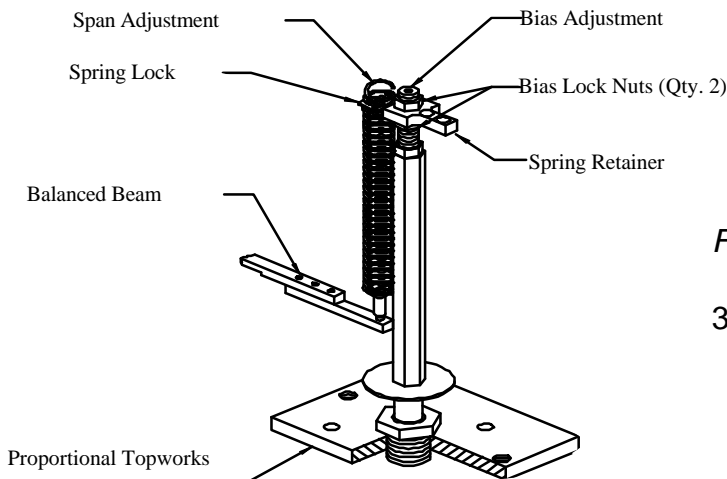

## **Bias Adjustment**

*For Standard (Non-split range) Systems:*

1. To *increase* the bias setting, increase tension on the *range spring*. This is accomplished by either raising the spring retainer or screwing the bias adjustment stud into the indicator bar or tail rod. Note the two jam nuts tightened against one another to adjust the length of the stud. When properly adjusted, tighten the bias lock nut(s).
2. In order to *decrease* the bias setting, decrease tension on the *range spring* by either lowering the spring retainer or screwing the bias adjustment stud out of the indicator bar or tail rod. Note the two jam nuts tightened against one another to adjust the length of the stud. When properly adjusted, tighten the bias lock nut(s).

*For Split Range Systems (see Table 1)*

3. Find the bias *adjustment screw* (1/2-20 thread with 3/8 flats) on the end of the positioner opposite the pneumatic signal input port. Loosen the jam nut located on the *adjustment screw*.
4. To *increase* the bias setting, tighten the *adjustment screw*.
5. To decrease the bias setting, loosen the *adjustment screw*.
6. Holding the *adjustment screw* in place, tighten the jam nut against the positioner body.

Spring	Range
Green (20-2592)	1-6
Silver (25-1038)	2-11
Blue (25-1036)	4-20
Red (25-1037)	8-30

**Table 1:** Adjustable Bias Springs

**Range Adjustment**

*Note:* There will be some interaction between range and bias adjustments. It may therefore be necessary to readjust the bias and re-check the range after completing the following steps.

The range, or the amount of travel between the lower and upper limits of the input signal, is set with the *range spring*. This range will typically be 12 psi for a 3-15 psi system or 24 psi for a 6-30 psi system. The limits of the range can be defined as the initial point at

Spring Range (psi)	Stroke (Part Number)			
	4	6	8	12
6	01-6288	01-6287	01-6287	01-6801
12	25-1151	25-1152	25-1153	25-1154
18	25-1599	25-1600	25-1601	25-1602
24	25-1218	25-1219	25-1220	25-1221

**Table 2:** Range Spring Configurations

Note: For intermediate ranges, use the next size range spring.

which the instrument signal to the **HPP-5** starts valve movement until the end of the valve stroke and full pressure differential across the cylinder output gauges.

1. After setting the bias for the start of the valve travel, continue increasing the instrument signal until the valve strokes is completed AND the cylinder output gauges show full power gas pressure differential.
2. Be sure not to overshoot at this point as any signal level above this upper limit will show the same reading on the cylinder gauges. This point is the highest end of the range and the value may not necessarily be equal to the desired upper range value.

3. If the range is less than desired (i.e. the actuator reaches its full travel in less than the specified input range), strengthen the *range spring* by winding it counterclockwise onto the *spring retainer*. If the range is greater than desired, weaken the *range spring* by winding it clockwise. Repeat adjustments until the desired range provides full or zero output pressure.
4. If the desired range is not achieved after making the above adjustments, readjust the bias (per the previous instructions) to allow proper range adjustment.
5. It may be necessary to change the *range spring retainer* for some non-standard ranges (refer to **Table 3**).

Type	Typical Use
Short (01-2509 )	8" and 12" Stroke
Intermediate (11-2572 )	6" Stroke
Long ( 01-2042 )	4" Stroke

**Table 3:** Range Spring Retainer

### **Changing Action of Positioner**

*To change the positioner from open on increasing signal to close on increasing signal, or vice versa, the following parts kits must be ordered:*

To change *open on increasing* to *close on increasing*: Part #25-1444 plus an Extension Rod (item #13 in drawing 35-0516, see **Table 4**). The serial number of the actuator must be specified. The exact part number of the extension rod will vary based on the actuator stroke.

To change *close on increasing* to *open on increasing*: Part #25-1289. **Note:** If converting a *close on increasing signal* positioner to *open on increasing signal*, the wide end of the tube (item #9) may be shortened by 11/16" with a hack saw in place of ordering part #25-1289.

The stroke length of the actuator cylinder **MUST** be specified when ordering the above part numbers. If the actuator serial number cannot be found, the stroke length can be found in the regulator model number. The stroke length is the first letter after the "H" in the model number. For example model 10H12L6FG-SR-S-HSB-40/35-100-O has a stroke length of "L", or 12 inches ["L" is the 12th letter in the alphabet]).

*Refer to the drawings 35-0515 and 35-0516 in the Appendix for the following:*

1. Disconnect all supply lines, instrument line, and output line from the positioner.
2. Remove the range spring (item #4) at both ends and those items connecting it to the rod (item #23) and the posi-

3. Remove the positioner from the bracket (item #18). The tubing and fittings on each side of the positioner must be taken off and installed in the opposite corner from their original position (see piping schematic provided by Becker Precision Equipment) then reattached to the positioner. This will allow the positioner to maintain the actuator failure mode when the positioner is turned upside down.
4. Move the bracket assembly (item #18), tube assembly (items #16 and #17), and cover plate (item #11) to the positions shown on the desired drawing.
5. Install the positioner in the opposite of its original position (upside down if it was right side up, right side up if it was upside down).
6. Using parts from the factory kit, assemble the spring and surrounding hardware according to the drawing of the desired configuration. (Note: all original parts may not be used when converting from *close on increasing* to *open on increasing*).
7. The entire bracket assembly (item #18) or the outer angle may need to be turned upside down to accommodate the new spring height.
8. Reconnect the supply, instrument, and output lines according to piping schematic supplied.

**Note:** *The flow direction must be maintained through the positioner bodies when re-piping. (I.e. the flow [supply or exhaust] moves from P1 to P2 and P3 to*

Stroke	With	Without
4	25-8265	25-8001
6	25-8136	25-1093
8	25-1402	25-1423

**Table 4:** Extension Rods for Positioners to Close on Increasing Signal

### Conversion to Split Range

*Converting a standard positioner to a split range positioner (pneumatic input other than 3-15 psi or 6-30 psi), requires ordering the proper conversion kit from the factory. This kit will include a bias spring and bias spring cartridge. If required, it will also contain a new range spring and mounting spacers.*

1. *For close on increasing positioner:*  
Remove the cap on the top of the positioner along with the spring inside it.  
*For open on increasing positioner:*  
Remove the mounting bracket holding the cap on the bottom of the positioner. Then remove this cap along with the spring inside it.
2. Replace the cap and spring with the larger bias spring cartridge and bias spring found in the kit. Make sure the bias adjustment screw in the bias spring cartridge is snug against the bias spring and the spring is centered before tightening the spring cartridge.
3. *For open on increasing positioner:*  
Remove the washer and jam nut from the adjusting screw in the bias spring

3. (Cont.) Reattach the mounting bracket upside down from its original position.
4. Slide the thread spacer (brass bushing) over the adjusting screw and tighten the washer and jam nut against the thread spacer.
5. If a range spring was sent with the kit, remove the existing range spring and replace it with the new one.
6. Adjust the unit per the Adjustment Procedures.

Stroke	Close on Increasing	Open on Increasing	Reference Drawings
4"	25-6014	25-1464	<i>Proportional:</i> 35-0513 35-0313/A 35-0511 35-0511/A  <i>Tailrod Mount:</i>
6"	25-6014	25-1465	<i>Proportional:</i> 35-0522
8"	25-6014	25-1466	<i>Tailrod:</i>

**Table 5:** Split Range Conversion Kits

**Note:** Refer to **Table 1** and **Table 2** for Bias and Range Spring part numbers.

## **Maintenance and Inspection**

As with all precision equipment, it is necessary to periodically test the positioner to ensure optimum performance. We recommend the following procedure once a year.

1. Shut off supply pressure and bleed down at positioner. Note the settings of the variable orifices and remove them from the orifice assembly. Clean them thoroughly and re-install using new o-rings, being sure to install each orifice in the same hole from which it was removed (the orifice and block have matching numbers for this purpose). Reset orifices to original settings. Turn on supply pressure.
2. Apply a midrange signal to the positioner. Allow the control valve to become stationary at about 50% of the range. Close the cylinder block valves or move the MCV-3 handle to the manual position. The positioner is now isolated from the cylinder. Apply a  $\pm \frac{1}{4}$  PSIG signal change. Observe the response in the output gauges. The output pressure should develop differential pressure equal to 20% of the power gas pressure. If the output pressure does not show immediate response, the positioner may have too much deadband. Reduce the deadband by turning the drum in the direction of decreasing numbers. If the pressures do not respond in the correct direction when reversing the instrument signal change, the unit has internal friction. Disassemble the unit and replace all rubber goods.
3. Check the integrity of the balanced
3. (Cont.) Check the integrity of the balanced valve seats by increasing the dead band by 1 full number. When the cylinder top and bottom gages are equal to the power gas, the exhaust port should not exhibit any bleed gas. If either of these tests fail, then the positioner is not properly adjusted or the unit needs to be reassembled with new rubber goods.
4. Soap test around all diaphragm interfaces, orifice assemblies and vents. If any leaks are found around the diaphragms, refer to the assembly instructions for replacement of all internal rubber parts.
5. Observe the operation of the gauges. If any gauges are defective, replace them.
6. Check range and bias. If necessary, readjust per Adjustment Procedures.

Should problems arise or more information is required, call toll free (800) 323-8844 for assistance

## Model HPP-5 Single-Acting Positioner Annual Maintenance Checklist

1. \_\_\_\_\_ **Soap test all diaphragm mating surfaces to check for leaks.**
2. \_\_\_\_\_ **Replace rubber goods utilizing Becker Model HPP-4 Single-Acting Positioner Repair Kit (Part # 30-9501) if necessary.**  
Refer to Pages 12-17, HPP-SB Assembly Procedures.
3. \_\_\_\_\_ **Confirm Power Gas Supply Pressure is correct.**  
Refer to original Becker invoice paperwork for proper power gas setting.
4. \_\_\_\_\_ **Observe operation of gages and replace if defective.**
5. \_\_\_\_\_ **Check integrity of HPP-4 positioner seats. Varying input signal 1 psig should send one cylinder output gauge to full power gas.**  
Refer to Procedure 7 note, pages 9, Adjustment Procedure.
6. \_\_\_\_\_ **Check response of HPP-4 positioner. Varying input signal 1/4 psig should produce cylinder output gauge differential equal to 40% of power gas.**  
Refer to Procedure 6-8, pages 8-9, Adjustment Procedure.
7. \_\_\_\_\_ **Check range and bias of HPP-4 positioner and adjust if necessary.**  
Refer to Pages 9-11 of adjustment procedure.
8. \_\_\_\_\_ **Inspect and Verify Proper Operation of all HPP-4 Positioner Accessories.**  
Refer to technical manual included with each specific instrumentation accessory for further instruction.

**Note: It is not necessary to replace any rubber goods in Becker**

instrumentation or instrumentation accessories on a regular basis. However, common practice suggests that replacement of rubber goods on a 5-year cycle basis provides adequate preventative maintenance.



**Parts Ordering**

The following is provided to allow the ordering of replacement parts. Please specify the Becker instrument serial number when ordering parts (this can be found on the Stainless Steel tab attached to the pilot by the 7/16 hex head cap screws. If the instrument was supplied as a complete valve regulator package, the Stainless tag attached to the actuator piston can also provide the serial number. See Drawing #30-0601

Key	Description	Part No.
1	Pilot base	30-7005
2	Lexan Cover	25-1034
3	Adjusting Drum	35-1520
4	Washer	25-1016
5	Inside piston	35-1507
6	Orifice Assembly	35-1015
7	Seat Cover	35-1519
8	1/2-20 Jam Nut	98-3056
9	Beam Adjusting Drum	25-1124
10	Diaphragm	25-1213
11		
12		
13	1/8 Roll Pin SS	98-2950
14	8-32 x 1" SHCS	98-3144
15	Beam Block	25-1086
16	Outside piston	25-1018
17	3/16 x 1/2 Roll Pin SS	98-3089
18	1/4-20 x 2-1/2 HHCS	98-3180
19	Gauge Manifold	35-1013
20	O-Ring -012	95-2615
21	1/4-28 Jam Nut	98-3214
22	Diaphragm w/ Convolute	25-1027
23	Beam Spacer	30-7055
24	1/4-20 x 1" HHCS	98-2579
25	3-15 pressure cartridge	25-1082
26	5-40 x 1/4 SHCS	98-2629
27	1/4-20 x 3/4 SHCS	98-3137
28	8-32 x 1/2 SHCS	98-2614

Key	Description	Part No.
29	Pilot Post S.S.	35-1521
30	Double pilot Body	35-1504
31	Valve Adjusting Screw	35-1517
32	Balance valve assembly	35-1510
33	Seat assembly	01-7082
34	S.S. Control tag	25-1061
35	10-32 x 3/8 FHMS	98-2684
36	#10 Lockwasher	98-3178
37	Strainer for Balance valve	35-1559
38	Seat Spacer	35-1526
39	Beam	25-1084

**Seal Kit**

A seal kit containing diaphragms, o-rings, and seats, for the HPP-5 positioner is available directly from Becker. Simply contact Becker Precision Equipment and order part number 30-9501

ITEM	QTY.	PART NO.	DESCRIPTION
1.	1	30-7005	PILOT BASE
2.	1	25-1034	LEXAN COVER
3.	1	35-1520	ADJUSTING DRUM
4.	4	25-1016	WASHER
5.	1	35-1507	INSIDE PISTON
6.	1	35-1015	DRIFICE ASSY.
7.	1	35-1519	SEAT COVER
8.	2	98-3056	1/2-20 JAM NUT
9.	1	25-1124	BEAM ADJUSTING DRUM
10.	1	25-1213	DIAPHRAGM
11.			
12.			
13.	1	98-2950	1/8 ROLL PIN SS
14.	4	98-3144	8-32 x 1" SHCS
15.	1	25-1086	BEAM BLOCK
16.	1	35-1506	OUTSIDE PISTON
17.	4	98-3089	3/16 x 1/2 ROLL PIN SS
18.	4	98-3180	1/4-20 x 2 1/2 HHCS
19.	1	35-1013	GAUGE MANIFOLD
20.	6	95-2615	O-RING -012
21.	1	98-3214	1/4-28 JAM NUT
22.	2	25-1027	DIAPHRAGM W/CONVOL.
23.	1	30-7055	BEAM SPACER
24.	6	98-2579	1/4-20 x 1" HHCS
25.	1	25-1082	3-15 PRESSURE CARTRIDGE
26.	1	98-2629	5-40 x 1/4 SHCS
27.	12	98-3137	1/4-20 x 3/4 HHCS
28.	2	98-2614	8-32 x 1/2 SHCS
29.	2	35-1521	PILOT POST SS
30.	1	35-1504	DOUBLE PILOT BODY
31.	1	35-1517	VALVE ADJ. SCREW
32.	2	35-1510	BALANCE VALVE ASSY.
33.	2	01-7082	SEAT ASSY.
34.	1	25-1061	SS CONTROL TAG
35.	2	98-2684	10-32 x 3/8 FHMS
36.	2	98-3178	#10 LOCKWASHER
37.	2	35-1559	STRAINER FOR B. V.
38.	2	35-1526	SEAT SPACER
39.	1	25-1084	BEAM

FIG. -1

FIG. -1

6" DIA. REF.

12

NOTES:

- ITEMS NO. 8, 24 AND 27 ARE TORQUED TO 95-100 in. lbs.
- ALL FASTENERS ARE STAINLESS STEEL.
- KIT#30-9501

APPROVED BY:	TS
DRAWN BY:	TS
DATE:	1-26-99
REVISION:	1.5/8
REVISED BY:	TS
SCALE:	1:1
HIGH PRESSURE POSITIONER	
MODEL#	HPP-5
DRAWING NUMBER	30-0601

